

Johannesburg Tourism Company NPC
A City of Johannesburg Metropolitan Municipality Entity

Req. No. 2003/009873/08

Sandton Library Offices	P.O Box 7776	Tel +27 11 779 0200
Nelson Mandela Square	Johannesburg	www.joburgtourism.com
West Street, Sandton	South Africa	
Johannesburg	2000	
South Africa		

REQUEST FOR QUOTATION (RFQ)

RFQ Number	JTC0052-2022/23
Description: REQUEST FOR QUOTATION TO APPOINT A SUITABLE AND QUALIFIED SERVICE PROVIDER FOR PRODUCTION OF FIXED DISPLAY MATERIAL, CAMPAIGN EXECUTION AND PROJECT MANAGEMENT: SECURING FLOOR SPACE, DESIGN, BUILDING, BREAKDOWN OF THE EXHIBITION STAND RAND EASTER SHOW 2023 JOBURG TOURISM COMPANY FROM 06 -10 APRIL 2023	
THIS REQUEST FOR PROPOSAL IS FOR THE JOHANNESBURG TOURISM COMPANY	

Date of advertisement:	15 February 2023
Closing date:	22 February 2023
Closing time:	10H00
Compulsory briefing meeting date (if applicable)	N/A
Quotations <u>MUST</u> be physically deposited in a TENDER box at: 4 th Floor Joburg Tourism Company Offices Sandton Library Offices Nelson Mandela Square West Street, Sandton	
Procurement Enquiries	mkhumalo@mbus.joburg.org.za Tel: (011) 779 0200
Technical Enquiries	Pontsho Moeketsi Pontshom@joburgtourism.com Tel: (011) 779 0200

Non-Executive Directors: Terry Tselane (Chairperson) | Bulelwa Koyana | Sakhumzi Maqubela | Ditaba Lucy Maraka Dr Umbigay Naidu

Executive Directors: Thato Davidson (Acting Chief Executive Officer) | Feroz Khan (Acting Chief Financial Officer)

ENTITY DETAILS

Entity Type	Private	Partnership	Close Corporation		Sole Proprietor
	Other (Specify)				
Entity Name	Legal Name:				
	Trading as:				
Entity Registration Number					
City of Johannesburg/ JTC Vendor Registration Number (if already have)					
National Treasury Central Supplier Database number: (Compulsory)					
Entity Street Address					
					Postal Code :
Contact Details of the Person Representing the Entity	Name	:			
	Telephone:	:			
	Cell phone:	:			
	E-mail address	:			
Income Tax Number					
VAT Reference Number (if applicable)					

PRICING SCHEDULE – FIRM PRICES

Bidder's Name:

- Johannesburg Tourism Company is not bound to accept the lowest or any quotation and reserves the right to accept the whole or any part of a quotation and to award the bid to more than one bidder.
- Offers to be valid for 60 days from the closing date of bid and no second-hand/refurbished materials/parts may be used in the final goods to be delivered by the bidder.
- Only firm prices will be accepted. Non-firm prices (including prices subject to rates of exchange variations) will not be considered in cases where different delivery points influence the pricing; a separate pricing schedule must be submitted for each delivery point.

- Do you intend to subcontract more than 25% of the work?

(Tick applicable box)

YES	NO
<input type="checkbox"/>	<input type="checkbox"/>

- If the answer is **YES**, indicate the name of the subcontractor _____, the percentage to be sub-contracted _____% and attach the BBBEE certificate of the subcontractor.
- The quotation will be evaluated on 80/20 preference point system in line with PPPFA Regulations, 2017.
- A bidder must submit proof of its B-BBEE status level of contributor to be awarded preference points, attach original or certified certificate (not older than 3 months) or sworn affidavit.
- For quotations above R30 000, the bidder should submit the municipal account for the company and all directors or lease agreement or an affidavit if they do not own or lease a property.
- B-BBEE Status Level of Contribution _____ (preference points, maximum 20) _____

- Other than completing the pricing schedule below, a bidder should submit the quotation on their company's letterhead or logos.

SCHEDULE OF PRICES/ RATES:

REQUEST FOR QUOTATION TO APPOINT A SUITABLE AND QUALIFIED SERVICE PROVIDER FOR PRODUCTION OF FIXED DISPLAY MATERIAL, CAMPAIGN EXECUTION AND PROJECT MANAGEMENT: SECURING FLOOR SPACE, DESIGN, BUILDING, BREAKDOWN OF THE EXHIBITION STAND RAND EASTER SHOW 2023 JOBURG TOURISM COMPANY FROM 06 -10 APRIL 2023

Pricing	(R)
Sub Total Price	
Vat 15% (if applicable)	
Total Quoted Price (Inclusive of Vat)	

MBD 4: DECLARATION OF INTEREST

1. No bid will be accepted from persons in the service of the state¹.
2. Any person, having a kinship with persons in the service of the state, including a blood relationship, may make an offer

or offers in terms of this invitation to bid. In view of possible allegations of favouritism, should the resulting bid, or part thereof, be awarded to persons connected with or related to persons in service of the state, it is required that the bidder or their authorised representative declare their position in relation to the evaluating/adjudicating authority.

3 In order to give effect to the above, the following questionnaire must be completed and submitted with the bid.

3.1 Full Name of Owner of the Bidding Entity:

3.2 Identity Number if applicable:

3.3 Position occupied in the Company (director, trustee, shareholder²):

3.4 Company Registration Number:

3.5 Tax Reference Number:

3.6 VAT Registration Number:

3.7 The names of all directors/ trustees/ shareholders' members, their individual identity numbers and state employee numbers must be indicated in paragraph 4 below

3.8 Are you presently in the service of the state?

(Tick applicable box)

YES	NO
<input type="checkbox"/>	<input type="checkbox"/>

3.8.1 If yes, furnish particulars.

3.9 Have you been in the service of the state for the past twelve months?

(Tick applicable box)

YES	NO
<input type="checkbox"/>	<input type="checkbox"/>

3.9.1 If yes, furnish particulars

3.10 Do you have any relationship (close family member, partner or associate) with persons in the service of the state and who may be involved with the evaluation and or adjudication of this bid?

(Tick applicable box)

YES	NO
<input type="checkbox"/>	<input type="checkbox"/>

3.10.1 If yes, furnish particulars

3.11 Are you aware of any relationship (close family member, partner or associate) between any other bidder and any persons in the service of the state who may be involved with the evaluation and or adjudication of this bid?

(Tick applicable box)

YES	NO
<input type="checkbox"/>	<input type="checkbox"/>

3.11.1 If yes, furnish particulars.....

3.12 Are any of the company's directors, trustees, managers, principle shareholders or stakeholders in the service of the state?

(Tick applicable box)

YES	NO
<input type="checkbox"/>	<input type="checkbox"/>

3.12.1 If yes, furnish particulars

3.13 Are any spouse, child or parent of the company's directors trustees, managers, principle shareholders or stakeholders in service of the state?

(Tick applicable box)

YES	NO
<input type="checkbox"/>	<input type="checkbox"/>

3.13.1 If yes, furnish particulars.....

3.14 Do you or any of the directors, trustees, managers, principle shareholders, or stakeholders of this company have any interest in any other related companies or business whether or not they are bidding for this contract?

(Tick applicable box)

YES	NO
<input type="checkbox"/>	<input type="checkbox"/>

3.14.1 If yes, furnish particulars:

.....

4. Full details of directors / trustees / members / shareholders. (Attach for additional members)

Full Name	Identity Number	State Employee Number (If applicable)

¹MSCM Regulations: “in the service of the state” means to be –

- (a) a member of – (i) any municipal council; (ii) any provincial legislature; or (iii) the national Assembly or the national Council of provinces;
- (b) a member of the board of directors of any municipal entity;
- (c) an official of any municipality or municipal entity;
- (d) an employee of any national or provincial department, national or provincial public entity or constitutional institution within the meaning of the Public Finance Management Act, 1999 (Act No.1 of 1999);
- (e) a member of the accounting authority of any national or provincial public entity; or
- (f) an employee of Parliament or a provincial legislature.

² Shareholder” means a person who owns shares in the company and is actively involved in the management of the company or business and exercises control over the company.

MBD8: DECLARATION OF BIDDER'S PAST SUPPLY CHAIN MANAGEMENT PRACTICES

1. This Municipal Bidding Document must form part of all bids invited.

2. It serves as a declaration to be used by municipalities and municipal entities in ensuring that when goods and services are being procured, all reasonable steps are taken to combat the abuse of the supply chain management system.

3. The bid of any bidder may be rejected if that bidder, or any of its directors have:
 - a. abused the municipality's / municipal entity's supply chain management system or committed any improper conduct in relation to such system;
 - b. been convicted for fraud or corruption during the past five years;
 - c. wilfully neglected, reneged on or failed to comply with any government, municipal or other public sector contract during the past five years; or
 - d. been listed in the Register for Tender Defaulters in terms of section 29 of the Prevention and Combating of Corrupt Activities Act (No 12 of 2004).

4. **In order to give effect to the above, the following questionnaire must be completed and submitted with the bid. (Tick applicable box).**

Item	Question	Yes	No
4.1	<p>Is the bidder or any of its directors listed on the National Treasury's database as a company or person prohibited from doing business with the public sector?</p> <p>(Companies or persons who are listed on this database were informed in writing of this restriction by the National Treasury after the <i>audi alteram partem</i> rule was applied).</p>	Yes <input type="checkbox"/>	No <input type="checkbox"/>

Item	Question	Yes	No
4.1.1	If so, furnish particulars:		
4.2	Is the bidder or any of its directors listed on the Register for Tender Defaulters in terms of section 29 of the Prevention and Combating of Corrupt Activities Act (No 12 of 2004)? (To access this Register enter the National Treasury's website, www.treasury.gov.za, click on the icon "Register for Tender Defaulters" or submit your written request for a hard copy of the Register to facsimile number (012) 3265445).	Yes <input type="checkbox"/>	No <input type="checkbox"/>
4.2.1	If so, furnish particulars:		
4.3	Was the bidder or any of its directors convicted by a court of law (including a court of law outside the Republic of South Africa) for fraud or corruption during the past five years?	Yes <input type="checkbox"/>	No <input type="checkbox"/>
4.3.1	If so, furnish particulars:		
Item	Question	Yes	No
4.4	Does the bidder or any of its directors owe any municipal rates and taxes or municipal charges to the municipality / municipal entity, or to any other municipality / municipal entity, that is in arrears for more than three months?	Yes <input type="checkbox"/>	No <input type="checkbox"/>
4.4.1	If so, furnish particulars:		

Item	Question	Yes	No
4.5	Was any contract between the bidder and the municipality / municipal entity or any other organ of state terminated during the past five years on account of failure to perform on or comply with the contract?	Yes <input type="checkbox"/>	No <input type="checkbox"/>
4.7.1	If so, furnish particulars:		

CERTIFICATION

I, THE UNDERSIGNED (NAME)

CERTIFY THAT THE INFORMATION FURNISHED ON THIS DECLARATION FORM IS CORRECT.

I ACCEPT THAT THE STATE AND/OR THE EMM MAY ACT AGAINST ME SHOULD THIS DECLARATION PROVE TO BE FALSE.

.....
Signature

.....
Date

.....
Capacity

.....
Name of Bidding Entity

MBD 9: CERTIFICATE OF INDEPENDENT BID DETERMINATION

1. This Form "I" must form part of all bids¹ invited.
2. Section 4 (1) (b) (iii) of the Competition Act No. 89 of 1998, as amended, prohibits an agreement between, or concerted practice by, firms, or a decision by an association of firms, if it is between parties in a horizontal relationship and if it involves collusive bidding (or bid rigging).² Collusive bidding is a *pe se* prohibition meaning that it cannot be justified under any grounds.
3. Municipal Supply Regulation 38 (1) prescribes that a supply chain management policy must provide measures for the combating of abuse of the supply chain management system, and must enable the accounting officer, among others, to:
 - a. take all reasonable steps to prevent such abuse;
 - b. reject the bid of any bidder if that bidder or any of its directors has abused the supply chain management system of the municipality or municipal entity or has committed any improper conduct in relation to such system; and
 - c. cancel a contract awarded to a person if the person committed any corrupt or fraudulent act during the bidding process or the execution of the contract.
4. This Form "I" serves as a certificate of declaration that would be used by institutions to ensure that, when bids are considered, reasonable steps are taken to prevent any form of bid-rigging.
5. In order to give effect to the above, the attached Certificate of Bid Determination must be completed and submitted with the bid:

CERTIFICATE OF INDEPENDENT BID DETERMINATION (MBD 9)

I, the undersigned, in submitting the accompanying bid:

(Bid Number and Description)

in response to the invitation for the bid made by: **Johannesburg Tourism Company** do hereby make the following statements that I certify to be true and complete in every respect:

I certify, on behalf of:

that:

(Name of Bidder)

1. I have read and I understand the contents of this Certificate;
2. I understand that the accompanying bid will be disqualified if this Certificate is found not to be true and complete in every respect;
3. I am authorized by the bidder to sign this Certificate, and to submit the accompanying bid, on behalf of the bidder;
4. Each person whose signature appears on the accompanying bid has been authorized by the bidder to determine the terms of, and to sign, the bid, on behalf of the bidder;
5. For the purposes of this Certificate and the accompanying bid, I understand that the word “competitor” shall include any individual or organization, other than the bidder, whether or not affiliated with the bidder, who:
 - (a) has been requested to submit a bid in response to this bid invitation;
 - (b) could potentially submit a bid in response to this bid invitation, based on their qualifications, abilities or experience; and
 - (c) provides the same goods and services as the bidder and/or is in the same line of business as the bidder
6. The bidder has arrived at the accompanying bid independently from, and without consultation, communication, agreement or arrangement with any competitor. However communication between partners in a joint venture or consortium³ will not be construed as collusive bidding.

-
- 7. In particular, without limiting the generality of paragraphs 6 above, there has been no consultation, communication, agreement or arrangement with any competitor regarding:
 - a) prices;
 - b) geographical area where product or service will be rendered (market allocation)
 - c) methods, factors or formulas used to calculate prices;
 - d) the intention or decision to submit or not to submit, a bid;
 - e) the submission of a bid which does not meet the specifications and conditions of the bid; or
 - f) bidding with the intention not to win the bid.

 - 8. In addition, there have been no consultations, communications, agreements or arrangements with any competitor regarding the quality, quantity, specifications and conditions or delivery particulars of the products or services to which this bid invitation relates.

 - 9. The terms of the accompanying bid have not been, and will not be, disclosed by the bidder, directly or indirectly, to any competitor, prior to the date and time of the official bid opening or of the awarding of the contract.

 - 10. I am aware that, in addition and without prejudice to any other remedy provided to combat any restrictive practices related to bids and contracts, bids that are suspicious will be reported to the Competition Commission for investigation and possible imposition of administrative penalties in terms of section 59 of the Competition Act No. 89 of 1998 and or may be reported to the National Prosecuting Authority (NPA) for criminal investigation and or may be restricted from conducting business with the public sector for a period not exceeding ten (10) years in terms of the Prevention and Combating of Corrupt Activities Act No. 12 of 2004 or any other applicable legislation.

.....
Signature	Date
.....
Full Names of Person Representing Company	Position in Company

FORM "E"

BRIEF OVERVIEW

Johannesburg Tourism Company (JTC) seeks quotations from qualified, suitable, registered service providers to secure floor space, design, build and breakdown of exhibition stands for participating at the Rand Easter Show from 06 to 10 April 2023 at Nazrec Expo Centre- Johannesburg. Service providers are to submit costs with **proposed exhibition stand sample for JTC at show**, taking into consideration all the Covid-19 protocols.

Programme of events

Date	Activity	Venue
03.04.2023	Build Up of JTC stand	Nazrec Expo Centre, Johannesburg
04.04.2023	Completion of JTC stand	
05.04.2023	Hand- over of JTC stand	
06.04.2023	10h00 - 17h00 Exhibition	
07.04.2023	10h00 – 17h00 Exhibition	
08.04.2023	10h00 – 17h00 Exhibition	
09.04.2023	10h00 -17h00 Exhibition	
10.04.2023	10h00 -17h00 exhibition	
11.04.2023	Breakdown	

SPECIFICATION/SCOPE OF WORK/TERMS OF REFERENCE

Request qualified and experienced Travel Management Company to respond on the following:

No.	Services	Required	Supplier Quote (Yes/No)
(a)	Production of fixed display material, campaign execution and project management: securing floor space, design, building, breakdown of the exhibition stand for participation of JTC at Rand Easter Show from 06 to 10 April 2023 at Nazrec Expo Centre, Johannesburg	Yes	

1. SCOPE OF WORK

Request qualified, registered and suitable service providers to submit quotation to secure floor space, design, build and breakdown of exhibition stands for participating at the Rand Easter Show from 06 to 10 April 2023 at Nazrec Expo Centre- Johannesburg. Service providers are to submit costs with **proposed exhibition stand sample for JTC at show**, taking into consideration all the Covid-19 protocols.

Rand Easter Show: 06 to 10 April 2023

Venue: Nazrec Expo Centre, Johannesburg

Stand number: TBA

See floor plan attached

Stand dimensions: 54sqm

Show Days: 06 to 10 April 2023

Note: Complete stand must be handed over to Tourism on 05 April 2023 at 17h00

Pavilion must comprise of below specifications:

- 1 x reception area
- 1 x public area
- 1 x storage facility
- 10 x SMME exhibition space

Reception Area

- 1 x reception counter with Covid -19 PVC screen and lockable cabinet
- 2x high chairs
- 1x Plasma screen (48 inch) , USB user friendly to plug in and showcase destination presentation at reception
- 2 x brochure stand to fit A4 size brochures with 6 tiers

Public Area: Lounge set up

- 1 x rectangular coffee table
- 1 x two seater couch
- 2 x one seater small couches

Storage facility within the stand

- 1 x lockable storage facility for brochures
- 1 x one mini bar fridge
- 20 x parking vouchers at the Nazrec Expo Centre for the duration of the show.

SMME exhibition space

SMME exhibition spaces within the main Tourism pavilion strategically spaced and branded meeting all Covid -19 protocols

- 10 x Counter – with the Covid-19 protection screen and lockable cupboard
- 10 x chairs for each counter for the exhibitors
- Space per cubicle for the SMMEs is 5mx5m

The counter will be branded with Joburg Tourism logo at the bottom as well as the Company name for the exhibitor.

Sample of the counter for the SMME exhibitors:

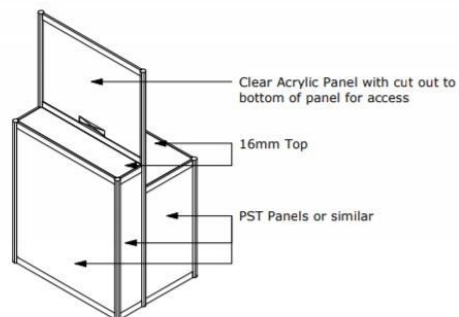



Sample of the proposed stand look.

Note well:

The main Tourism Pavilion must have the reception area and lounge/public area and enough space for activation and allowance for social distancing in line with Covid -19 protocols. The pavilion must be branded with Joburg tourist attraction images namely but NOT limited to the suggested;

- Red bus, Orlando Towers, Nelson Mandela Bridge, Shopping, Eating out, bungee jumping, Quad-biking, Joburg Zoo, Hiking spots, hotels, etc. The appointed service provider need to source the images at OWN cost and follow all the necessary disclaimer and public use of the images as JTC will NOT be liable for any litigation as a result of use of images. Please note that the pavilion area needs to allow for ease of movement and enough air circulation during the exhibition.

1.1 Summary Pricing Schedule – Rand Easter Show: Nazrec Expo Centre

Item	QTY	PRICE/ UNIT	TOTAL PRICE
Exhibition stand design, build and breakdown	1	R	R
Floor space size 54sqm as quoted by the organiser	1		
TV monitor/screen (USB friendly)	1		
Reception counter with lockable storage	1		
A4 brochure stands with 6 zig zag tiers	2		
High chairs (bar chairs) at reception	2		
Mini bar fridge	1		
2 black seater couch in the public area	1		
1 black seater couch in the public area	1		
1 rectangular coffee table in the public area	1		
Counter – with the Covid-19 protection screen and lockable cupboard	10		
Office chairs	10		
Parking vouchers	20		
Photographer for 27 September 2022 from 10h00 to 14h00	1		
TOTAL PRICE excl VAT			
VAT			
TOTAL PRICE incl VAT			

CHECKLIST

Checklist documents and requirements should be attached and submitted with the bid on submission as failure to do so **will lead to disqualification.**

Documents required to be attached :-	Attached	
	Yes	No
Quotation on company letter head.		
Only companies with minimum five (3) years' experience in <u>Travel and Tourism Stand exhibition building and setting up exhibition stands at local and international tourism trade shows</u> should respond.		
All parts must be quoted.		
Respondents must submit their response (quote) <u>with 3 examples of work done</u> by the company at tourism trade exhibition;		
Valid certified BBBEE certificate or affidavit.		
Valid Tax Clearance certificate		
CSD registration number to be filled in on the front page of RFQ in clear handwritten		
Completed RFQ		
Municipal Account not in arrears for more than 90 days for all <u>Directors</u> or lease agreement if leasing a property or affidavit if the company and directors are nether leasing nor own a property.		
Municipal Account not in arrears for more than 90 days for the <u>Company</u> with the address appearing on CSD report or lease agreement if leasing a property or affidavit if the company are nether leasing nor own a property.		